

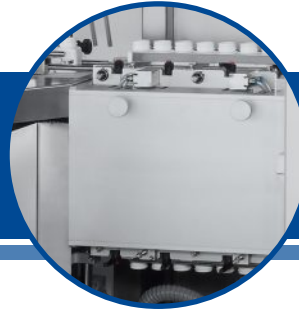

BOTTLE AIR RINSER

CVC 1102



The CVC 1102 Bottle Air Rinser is Equipped with powerful clean air jet and vacuum suction which are combined with 180-degree inversion of bottle at speeds of up to 80 bottles per minute. The CVC 1102 series Automatic Bottle Air Rinser are the ideal solution for oral products lines to achieve cGMP compliance.

Different bottle sizes are easily change over with customized bottle format change parts.

STANDARD FEATURES

- Display touchscreen instruction for machine operation is available in two languages.
- Interlocked safety guarding.
- Bottle backlog sensor at outfeed.
- Type 304 stainless steel bin, frame, enclosure panels.
- Type 316 stainless steel contact parts.
- ISO 9001:2015 certified.



CVC 1102 Technical Specifications

Type	U4.4
Speed	Up to 80 Bottles per Minute (BPM)
Bottle Height	2" to 5 7/8" (50mm - 150mm)
Bottle Diameter	1 1/8" to 3 1/8" (30mm - 80mm)
Power Source	220V, 50 Hz, 1 Phase
Power Consumption	5.5 Amp (equipped with Air Rinse & Vacuum)
Air Pressure	Minimum 87 psi (ISO 8573-1)
Air Consumption	1.75 cfm (50 L/min.) on standard machine without optional ionized air rinse assembly.
Machine Dimensions	5'-6" x 3'-5" x 4'-8" (1680 x 1050 x 1432 mm) (L x W x H)
Machine Weight	1124 lbs. (510 kg)
Packing Weight	1234 lbs. (560 kg)
Noise Level	78 dB

TECHNICAL SPECIFICATIONS

AVAILABLE OPTIONS

- Static Electricity Eliminator
- Vacuum block detection assembly
- Tower lamp
- 21CFR Part 11 License

MACHINE LAYOUTS

Top View

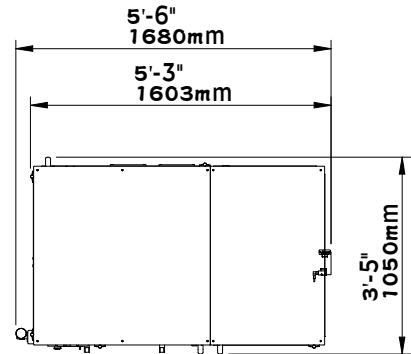

Front View

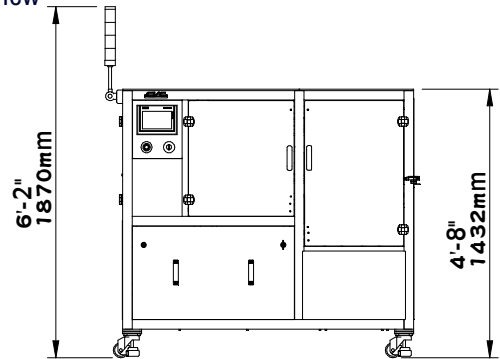

The dimensions shown are for standard machine. The conveyor can be extended: the length may vary based on selected options. This machine can run independently or be integrated into an automated packaging line. All CVC equipment is covered by a one-year parts warranty. Full Warranty details are included in our equipment proposals or can be found on our website.



Contact Us

USA

10861 Business Drive, Fontana, CA 92337
Phone: +1 (909) 355-0311
www.cvctechnologies.com
sales@cvcusa.com

USA East Coast Office

1855 New Highway, Suite C, Farmingdale NY 11735
sales@cvcusa.com

Taiwan-Asia Pacific Headquarters

Phone: +886 (4) 2496-3666
sales@cvctechnologies.com

China/India/Indonesia

sales@cvctechnologies.com